

## Application to place a builder's skip on the highway

Highways Act 1980, Section 139, 140 and 140A

Please complete the following information in capitals and return to the address below. You must give a minimum notice of five working days before you intend to deposit the skip. The skip may not be deposited on the highway without written confirmation that the permit has been authorised.

Proposed location of skip	
<b>Name:</b>	
<b>Address:</b>	
	<b>Postcode:</b>
<b>Out of hours tel. number:</b>	
<b>From (date and time)</b>	
<b>To (date and time)</b>	

Skip operator/owner details		
<b>Name:</b>		
<b>Address:</b>		
	<b>Postcode:</b>	
<b>Daytime tel. number:</b>	<b>Out of hours tel. number:</b>	
<b>Fax Number</b>		
<b>Email address</b>		

Continued over

**I/We hereby apply to North Somerset Council for permission to deposit .....(number) builder's skip(s) on the highway at the above location and hereby agree to comply with the terms and conditions set out as attached and with all other statutory rules and regulations which may apply in these circumstances.**

<b>Fee enclosed:</b>	<b>£</b>
<b>Signed</b>	
<b>Position in company</b>	
<b>Name (Block Capitals)</b>	
<b>Date</b>	

Data Protection Act 1998

The personal data you provide on this form will be used by North Somerset Council to administer your permit. In order to protect public safety, this may include the use of sensitive personal data (criminal offences) to help assess whether you are a fit and proper person to hold a permit.

We may occasionally share your personal data with other Council departments and with other bodies (notably Housing Benefits, the Police, Inland Revenue) for the purposes of protecting public money, preventing and detecting crime and/or fraud and ensuring public safety. Such sharing will only occur on a case-by-case basis where a justifiable purpose in line with legislation has been demonstrated. The information may also be used for internal training.

Office Use Only

Licence Number				Confirm Ref:	
Granted		Refused		Receipt No.	

# Application Notes

## 1. General

A Permit is required when a skip is placed on the highway. The term highway includes both footpaths and roads. We do not though give permissions in relation to locating skips on footpaths or Council land such as verges or open spaces. Also permissions are not generally granted for weekend periods in the town centre of Weston-super-Mare or when large events are taking place. It is an offence under the Highways Act 1980 place a skip on the highway without first obtaining a permit from North Somerset Council. Failure to obtain the required permit could result in legal action being taken by the Council for which the current maximum fine on conviction is £1,000.

## 2. Application Procedure

A completed application along with the permit fee and a copy of a valid certificate of public liability insurance (first time applications only) must be submitted to the Licensing Office before a skip is placed on a highway. The application can be made in person or by post (see below for our contact details). If we have agreed payment of fees on an account basis, applications can be made by fax.

## 3. Conditions attached to Permits

Conditions will be attached to permits that we issue and these are shown on overleaf.

## 4. Notification of completion of works

Included with permissions issued will be a separate sheet (form LHF01) for completion and return to the Licensing Office. This form should be completed and preferably faxed to the Licensing Office no later than three working days after the skip has been removed from the highway. The fax number for the Licensing Office is given below. Failure to notify us of the removal of a skip may result in an additional permit fee being charged for any period beyond the expiry of the permit.

## 5. Extension of a Permit

All permits issued are time specific and expire on the date stated on the permit. If a further time is required beyond the period of use granted on the permit, a further application will have to be made to North Somerset Council. The application must be made no later than five working days before the expiry of the current permit.

## 6. Further Information

If you require any further information regarding applying for a permit, or assistance in regard of a permit that has been granted, please contact us as detailed below:

<b>Address:</b>	The Licensing Office Warne Road Depot, Warne Road, Weston-super-Mare, North Somerset, BS23 3ND
<b>Telephone:</b>	01934 426 800
<b>Fax:</b>	01934 426 230
<b>Email:</b>	<a href="mailto:licensing@n-somerset.gov.uk">licensing@n-somerset.gov.uk</a>

# Conditions for siting a builder's skip on the highway

Highways Act 1980, Section 139, 140 and 140A

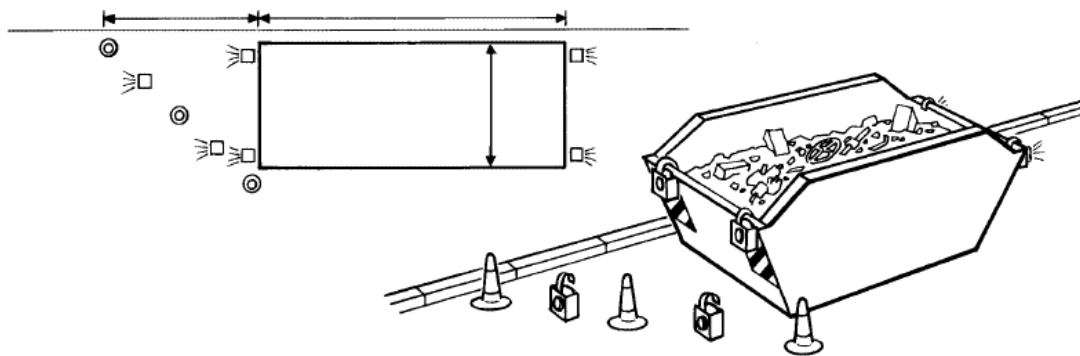

## A. Specifications for builder's skips

1. Builder's skips for use on the highway for the disposal of building material, rubbish or other matter shall comply with the appropriate Motor Vehicles (Construction and Use) Regulations when carried on the vehicle.
2. All signing, coning and lighting of builder's skips must be in accordance with Chapter 8 of the Traffic Signs Manual 1991 and must meet all of the requirements listed below and be maintained in good order throughout the duration of the permission.
3. The builder's skip shall not exceed five metres in length and two metres in width.
4. The ends of each skip shall be painted yellow and marked with vertical red fluorescent and yellow reflective markings adjacent to the outer edge of each end of the container in accordance with the Builder's Skips (Markings) Regulations and BS AU 152. The markings shall be kept clean at all times.
5. The container shall be clearly and permanently marked with the owner's name, address and telephone number.

## B. Positioning of the builder's skips

1. Where more than one skip is on the highway at any one time, the skips shall be positioned as closely as possible to each other, but not to obstruct access to any premises unless the consent of the occupier has been obtained.
2. The skip shall not be placed within a distance of 15 metres of a road junction, nor in major shopping areas and their access roads during such times as Christmas, sales etc. nor near public meeting places such as churches, schools, football grounds etc.
3. It shall not be placed in a bus lane during the period of its operation.
4. It shall not be placed in such a position to impede surface water drainage nor obstruct access to fire hydrants, gullies, manholes and apparatus of any Statutory Undertaker. Nor be placed in such a position as to contravene Traffic Orders or Regulations made under the Road Traffic Acts.
5. Each skip will be guarded by at least four cones placed in an oblique line on the approach side of the skip.
6. Between half an hour after sunset and half an hour before sunrise the skip must have placed, lit and maintained road danger lamps (flashing amber) attached at each corner and between each cone.
7. Consent is granted on the understanding that it is not possible to place the skip(s) on private land without undue difficulty.

The Licensing Team, Warne Road Depot, Warne Road, Weston-super-Mare, North Somerset, BS23 3ND.

Tel: 01934 426 800, Fax: 01934 426 230, email [licensing@n-somerset.gov.uk](mailto:licensing@n-somerset.gov.uk)

### C. Maintenance of skips on the highway and general conditions

1. The skip owner must indemnify and save harmless the council against all claims related to the use of the skip(s) and shall maintain a third party insurance policy providing at least £5 million cover for any claim arising out of one incident. This policy is to be produced to the council when so required.
2. No skip when standing on the highway shall contain any inflammable, explosive, noxious or dangerous material or any material which is likely to putrefy or which otherwise is, or likely to become, a nuisance to users of the highway. All waste placed in skips shall be deemed to controlled waste as defined by the Environmental Protection Act 1990 and be properly disposed of by a registered carrier to a licensed site and the highway where the skip have been deposited shall be left in a clean and tidy condition.
3. No skip may remain on the highway after the consent date given on the permission form. Failure to observe the dates stated may lead to the skip being removed by the Highway Authority or police and any expenses incurred in such removal will be directly recoverable from the skip owner.
4. Each skip shall be removed for emptying as soon as practicable and in any case not later than two working days after it has been filled. It shall be removed or repositioned if required by the police or Director of Development and Environment or their representative.
5. The skip owner shall notify the Licensing Authority by fax or email no later than one working day after the removal of the skip from the highway.