

Application to deposit building materials on the highway

Highways Act 1980, Section 171

Please complete the following in capitals and return to the address below. No building materials should be deposited on the highway without confirmation in writing that a permit has been authorised by North Somerset Council. You must give a minimum notice of five working days before you wish to deposit any materials on a highway.

Applicant's details			
Name:			
Address:		Postcode:	
Office tel. number		Out of hours tel. number:	
Fax Number			
Email:			

apply for permission to North Somerset Council to deposit the materials listed below:

Description	Approximate quantity	Description	Approximate quantity
on the: (please tick)	carriageway	footway	verge
of	street name:		Town:
and outside: (property number or name)			
From:	date and time:	to:	date and time:

Continued over

I/We agree to comply with the terms and conditions set out overleaf and with all other statutory rules and regulations which may apply in these circumstances.

Signature: _____ **Date:** _____

Fee enclosed:	£
Signed	
Position in company	
Name (Block Capitals)	

Contact Details

The Licensing Team, Warne Road Depot, Warne Road, Weston-super-Mare, North Somerset, BS23 3ND.

Tel: 01934 426 800 Fax: 01934 426 230

Data Protection Act 1998

The personal data you provide on this form will be used by North Somerset Council to administer your permit. In order to protect public safety, this may include the use of sensitive personal data (criminal offences) to help assess whether you are a fit and proper person to hold a permit.

We may occasionally share your personal data with other Council departments and with other bodies (notably Housing Benefits, the Police, Inland Revenue) for the purposes of protecting public money, preventing and detecting crime and/or fraud and ensuring public safety. Such sharing will only occur on a case-by-case basis where a justifiable purpose in line with legislation has been demonstrated. The information may also be used for internal training.

Office Use Only

Licence Number				Confirm Ref:	
Granted		Refused		Receipt No.	

Application Notes

1. General

A Permit is required when building materials are deposited the highway. The term highway includes both footpaths and roads. It is an offence under the Highways Act 1980 to place building materials on the highway without first obtaining a permit from North Somerset Council. Failure to obtain the required permit could result in legal action being taken by the Council for which the current maximum fine on conviction is £10 for each day the contravention continued.

2. Application Procedure

A completed application along with the permit fee and a copy of a valid certificate of public liability insurance (first time applications only) must be submitted to the Licensing Office before building materials are placed on a highway. The application can be made in person or by post (see below for our contact details).

3. Conditions attached to Permits

Conditions will be attached to permits that we issue and these are shown on a overleaf.

4. Notification of completion of works

Included with permissions issued will be a separate sheet (form LHF04) for completion and return to the Licensing Office. This form should be completed and preferably faxed to the Licensing Office no later than three working days after the building materials have been removed from the highway. The fax number for the Licensing Office is given below. Failure to notify us of the removal of building materials may result in an additional permit fee being charged for any period beyond the expiry of the permit.

5. Extension of a Permit

All permits issued are time specific and expire on the date stated on the permit. If a further time is required beyond the period of use granted on the permit, a further application will have to be made to North Somerset Council. The application must be made no later than five working days before the expiry of the current permit.

6. Further Information

If you require any further information regarding applying for a permit, or assistance in relation to a permit that has been granted, please contact us as detailed below:

Address: The Licensing Office
Warne Road Depot,
Warne Road,
Weston-super-Mare,
North Somerset,
BS23 3ND

Telephone: 01934 426 800
Fax: 01934 426 230
Email: licensing@n-somerset.gov.uk

Conditions for depositing building materials on the highway

Highways Act 1980, Section 171

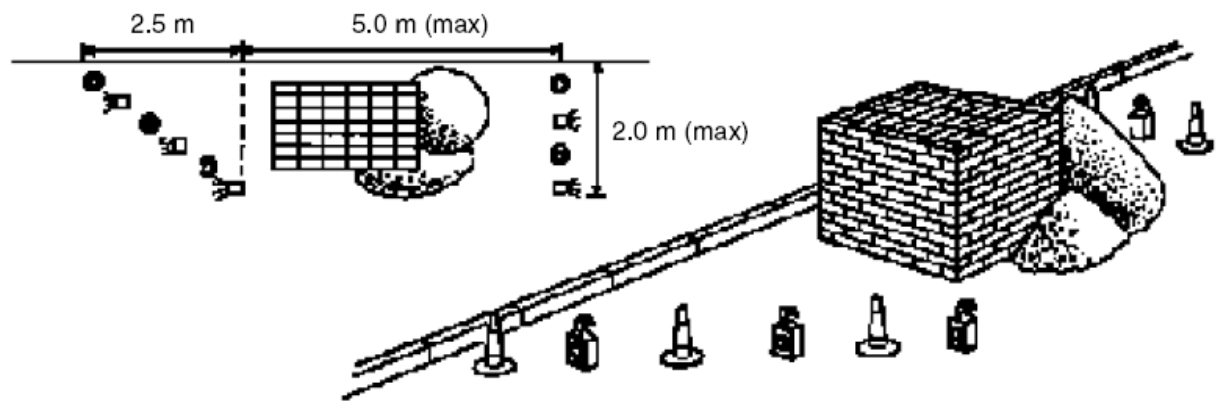

Duties of the licensee

The licensee must:

1. Place and keep at least five traffic cones on the highway (see diagram above) in daylight for each deposit
2. Keep and deposit under five metres long and two metres wide with a minimum of 15 metres between deposits
3. Not block the channel or gutter, nor allow material to enter drains
4. Not obstruct any gully or manhole
5. Not deposit any inflammable, explosive or noxious material
6. Not mix materials on the highway surface but a mixing board may be used. (Maximum Penalty £2,500 – see Section 170 Highways Act)
7. Clear the deposit by the time stated
8. Sweep and remove all spillage and debris from the highway
9. If the deposit is authorised to remain overnight:
place and maintain during lighting-up hours, a minimum of five road danger lamps (flashing amber) for each deposit (see diagram above)
10. Place and maintain warning signs as directed by North Somerset Council
11. **Immediately** remove the deposit at the request of any Statutory Undertaker who requires the site
12. Give a copy of this permit to the person receiving the materials
13. The permission holder shall notify the Licensing Authority by fax or email no later than one working day after the removal of the deposit from the highway.

Penalty for non-observance

If the council has to take action to remedy a breach in these conditions or to repair damage the full costs shall be recovered from the licensee.

Legal indemnity

The licensee shall indemnify and save harmless the council and/or its officers and agents against and from all claims, demands, actions, costs and damages however arising out of by or in consequence of the depositing of materials on the carriageway, footway, or verge. The period of indemnity to run from the commencement of the deposition to the final removal of the same.

Conditions to be observed by both supplier and owner of the deposit

Material shall not be deposited:

1. Within 15 metres of any road junction
2. In any bus lane during its period of operation
3. During the hours of darkness - unless specially authorised
4. Where parking restrictions or traffic measures are in force – unless specially authorised
5. In major shopping areas and their access roads during such times as Christmas, sales, etc.
6. Near public meeting places such as churches, schools, football grounds etc.