

Highway potholes

Service summary:

We must keep the highway network in a safe condition.

Not all holes in the road are classed as potholes. A pothole is a sharp edged hole in a road or path, usually caused by water or weather damage, or heavy vehicles.

To be classed as a carriageway pothole, it must be deeper than 40mm and more than 300mm across.

To be classed as a footway pothole, It must be deeper than 20mm and more than 600mm across.

Please see diagrams below.

Highway Authorities Definition of Damage to Pavements

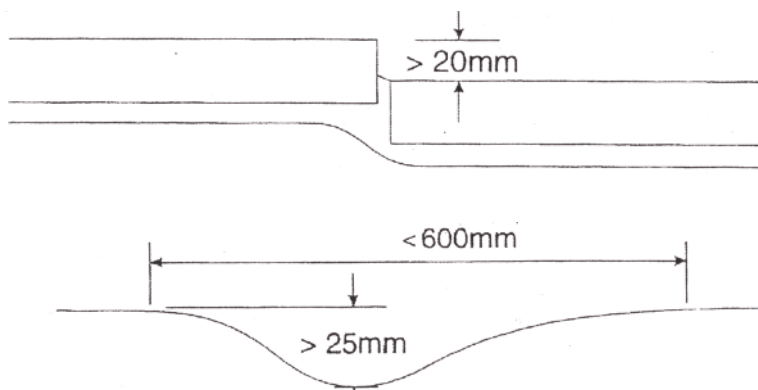

Highway Authorities Definition of Damage to Highways

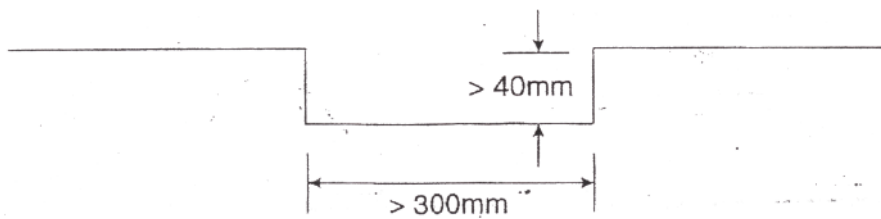

We will:

- repair dangerous potholes on roads and footways within 24 hours of being told about them
- repair 95% of other holes within 28 days of them being reported to us.

H

Highway potholes

You can help by:

- telling us about any pothole that is larger than the sizes above or you have concerns about.

The service does not include:

- potholes on private roads or paths.

Contact us:

01934 888 802

www.n-somerset.gov.uk

Streets and Open Spaces, North Somerset Council, Weston Court,
Oldmixon Crescent, Weston-super-Mare BS24 9AU

Frequently asked questions:

Highway potholes

1. My road is full of potholes - why aren't you repairing it?

Not all road surface faults are classed as potholes. Larger areas are more effectively repaired using different methods.

2. What is a pothole?

A pothole is defined as a sharp-edged hole:

- A carriageway pothole is deeper than 40mm and extends more than 300mm.
- A footway pothole is deeper than 20mm and extends more than 600mm.

3. Why don't you repair smaller holes?

We have to prioritise our repairs and so these defects are monitored by regular inspections and repaired as part of planned maintenance works. If they become potholes or need urgent attention for safety reasons we will repair them.

4. Why is the repair of poor quality?

To maintain the safety of the highway an immediate temporary repair is carried out. This is followed within 28 days by a permanent repair or repaired as part of larger planned works.